

HDM-ONE Instructions

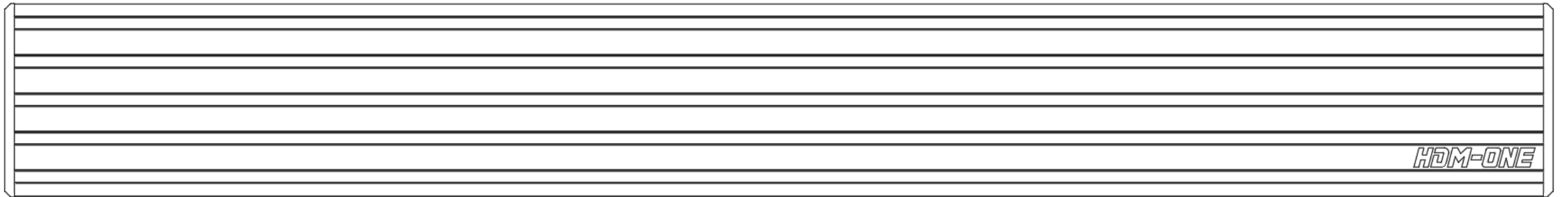

For video instructions visit hdmutah.com/instructions

Tools Required

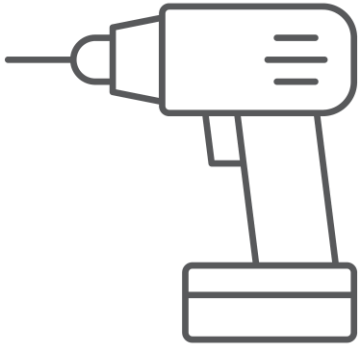

Drill

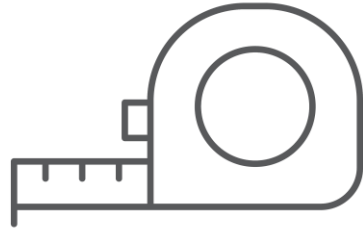

Tape Measure



Pencil



Stud Finder



1/2 inch Drill Bit



#2 Phillips Bit

HDM-ONE Wall Preparation: Step 1

- Locate the place you wish to mount the HDM-ONE
- Using the stud finder, locate 2 studs within your mounting range
NOTE: We recommend 2 studs for every 800mm of extrusion being mounted
NOTE: Use a MINIMUM of one stud mount and 2 supporting drywall mounts
- Mark the mounting height inline with the center of each stud
- Mark a 3rd and 4th spot on hollow drywall at the same height
NOTE: Maximum separation of end mounts is 30 inches / 762 mm for an 800 mm extrusion length
NOTE: Drywall mounts are not as strong as stud mounts, mounting to 2 studs is recommended

Tools Required

- Pencil
- Stud Finder
- Tape Measure

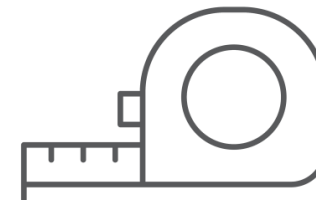

HDM-ONE Wall Preparation: Step 2

- Using a ½ inch drill bit, drill a hole in each hollow drywall mark
- Install the drywall anchors

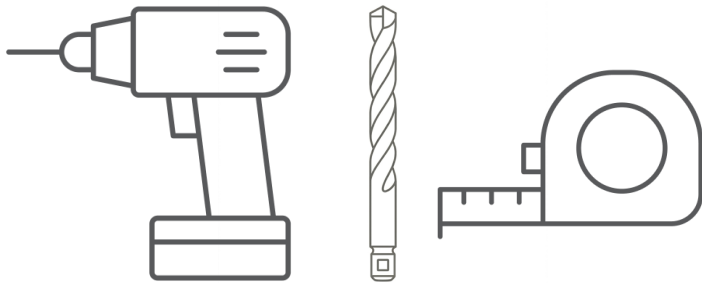

Tools Required

- Drill
- ½ inch Drill Bit
- Tape Measure

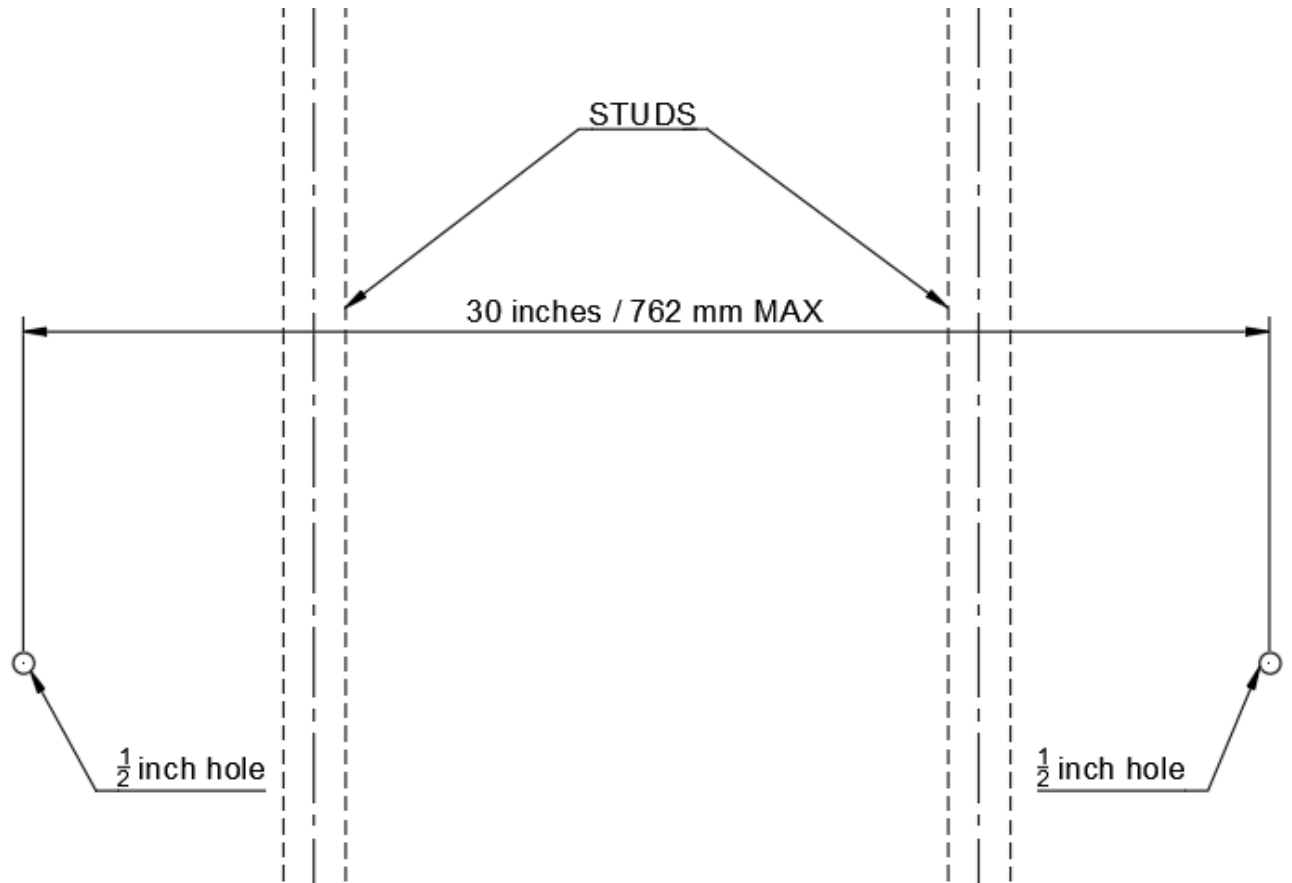

HDM-ONE Wall Mounting: Step 1

- Using a #2 Phillips Bit and #8 x 2 Wood Screws, install the STUD Mounts to the wall using the marks made on the studs

NOTE: Only use one screw in the slot of each STUD Mount for

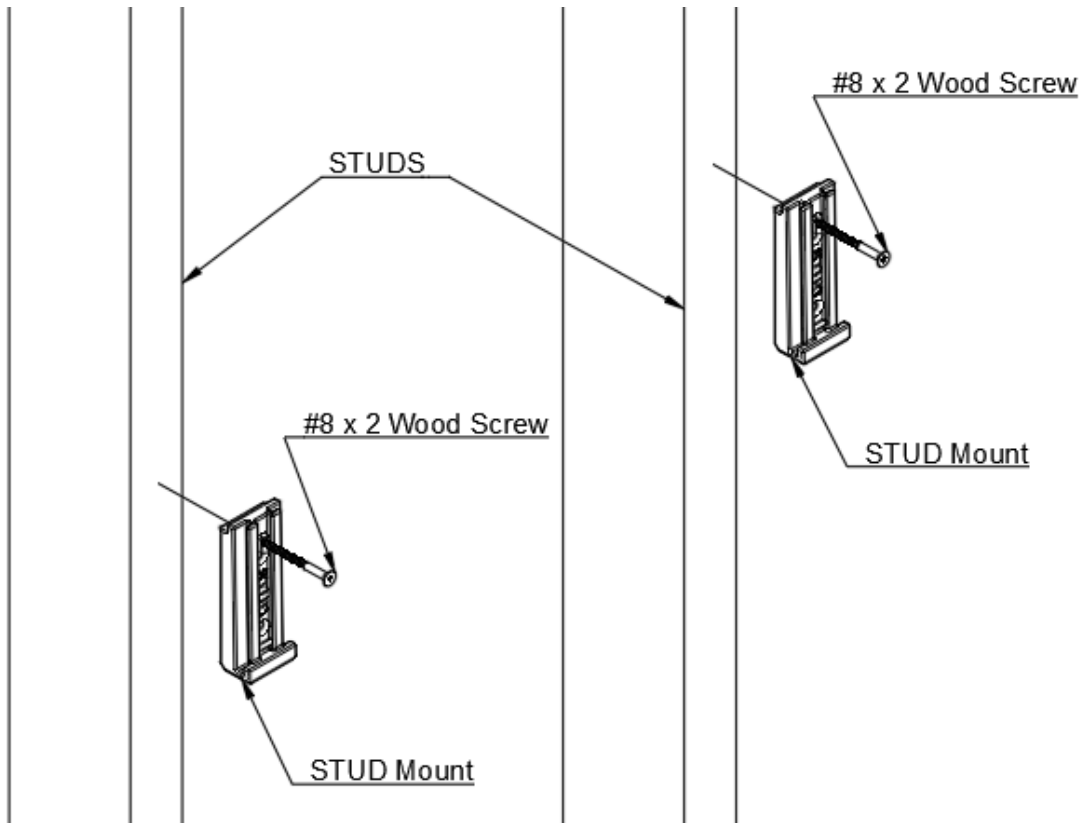

NOTE: Leave the screws loose enough to move the mount up and down using the slot

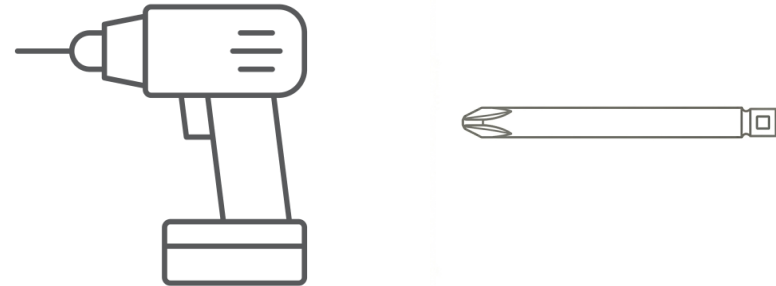

Tools Required

- Drill
- #2 Phillips Bit

HDM-ONE Wall Mounting: Step 2

- Using a #2 Phillips Bit and the drywall anchor screws, install the D-WALL Mounts to the drywall anchors

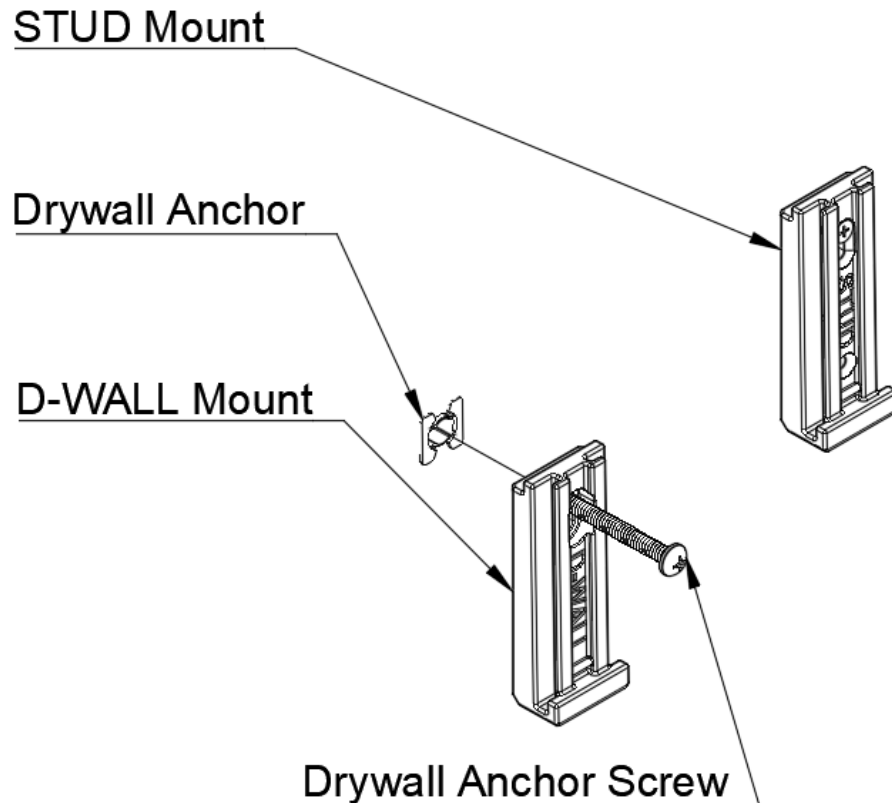

NOTE: Leave the screws loose enough to move the mount up and down using the slot

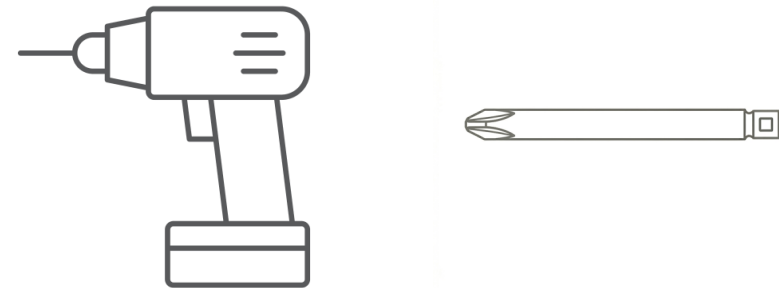

Tools Required

- Drill
- #2 Phillips Bit

HDM-ONE Wall Mounting: Step 3

- Using a tape measure, make sure that the top of each D-WALL and STUD Mount are at the same height
- Lock each mount in place using the drill and #2 Phillips Bit
- Install a #8 x 2 Screw into the bottom hole of each STUD Mount and tighten all screws

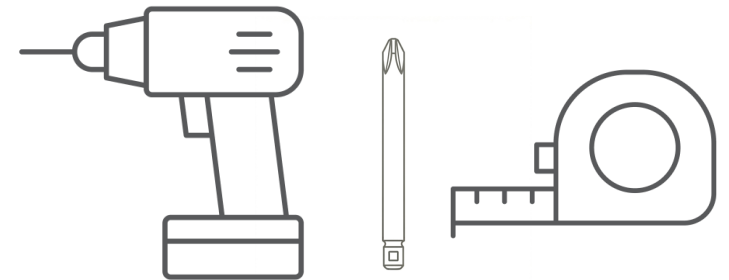
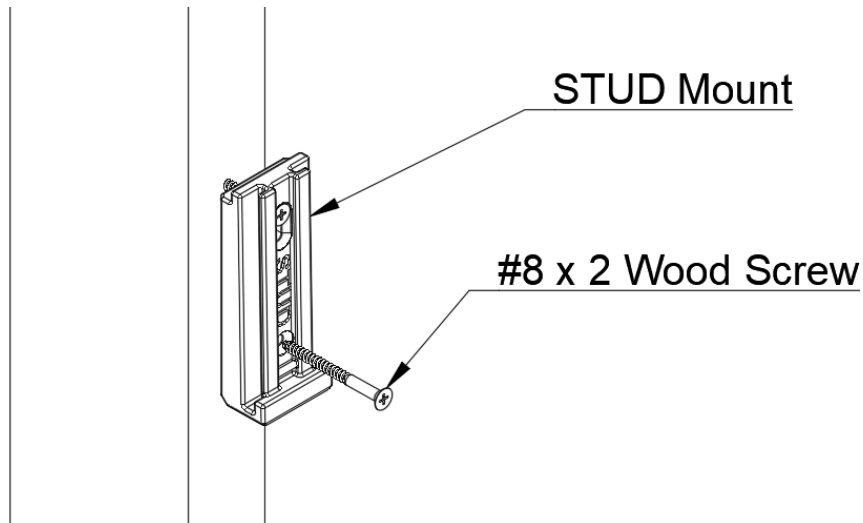

Tools Required

- Drill
- #2 Phillips Bit
- Tape Measure

HDM-ONE Wall Mounting: Step 4

- Line up the rear accessory mounts with the D-WALL and STUD Mounts
- Lock the rear accessory mounts to the extrusion using the M5 Screws and T Nuts
- Install the HDM-ONE onto the D-WALL and STUD Mounts

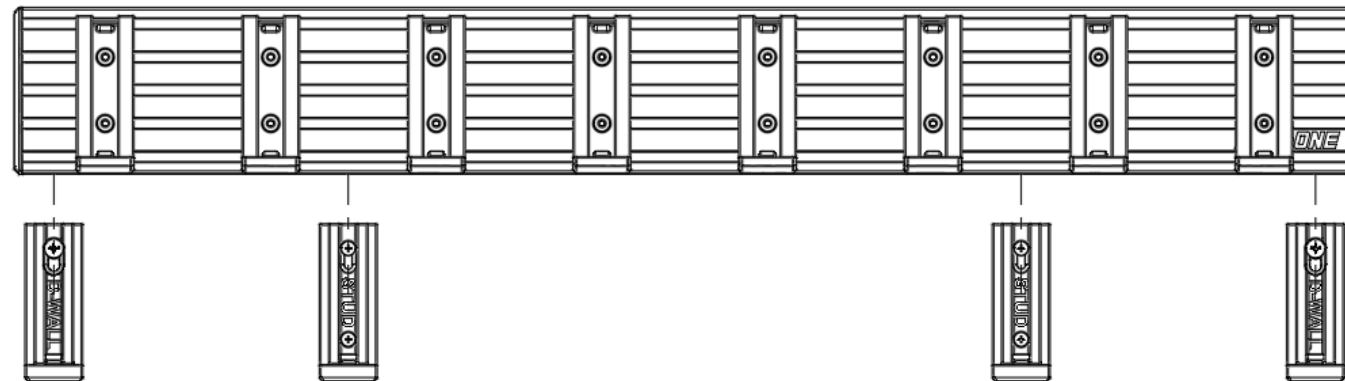
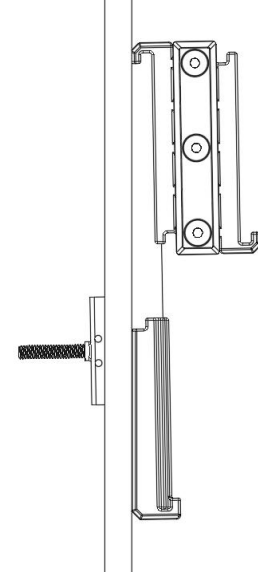

HDM-ONE Accessory Mounting: Step 1

- Place and position accessories and accessory mounts

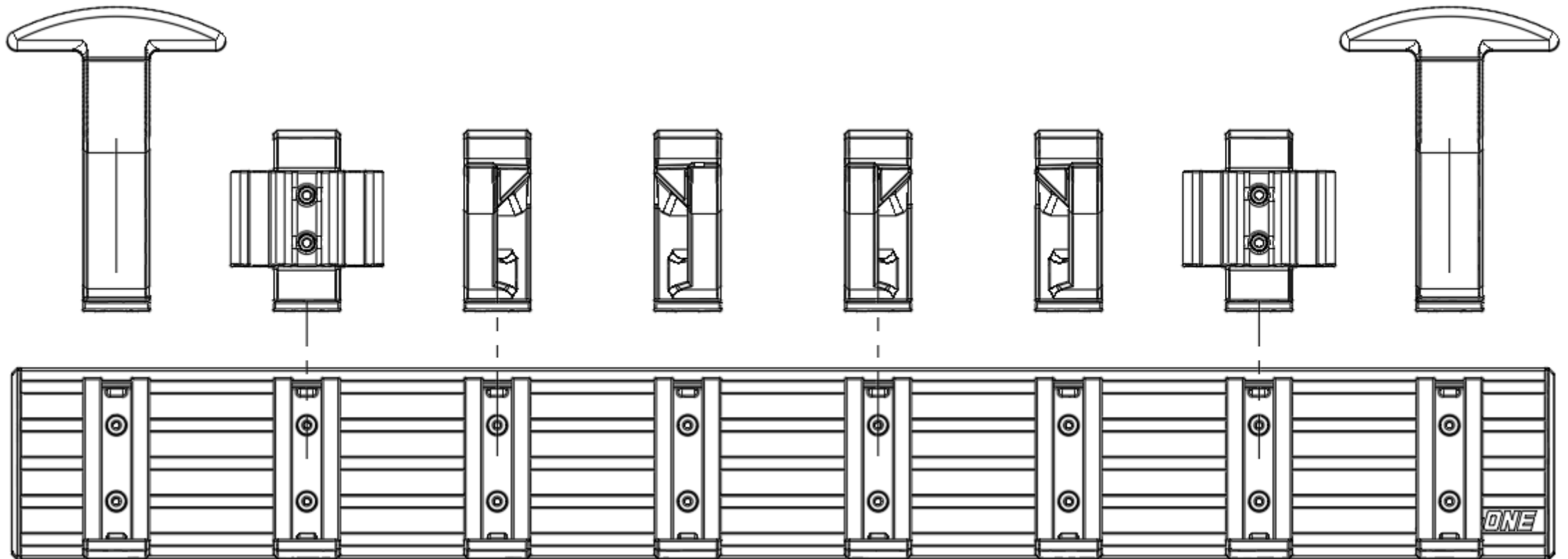

HDM-ONE Accessory Mounting: Step 2

- Once the location of each accessory is finalized, remove accessories and lock the accessory mounts using the M5 Screws and T Nuts
- Replace accessories and install gear
- Finished

